

# KTF-II Series Centrifugal Fan



## Arama & Benet

Air Engineering Solutions

info@arama-benet.com

www.arama-benet.com

PRODUCT NAME:  
KTF-II Series Centrifugal Fan

PRODUCT TYPE:  
KTF900A-II-45.0kW-4-90°L

Weight include motor:  
534 kg

Finish: Painted  
Color: RAL 7024

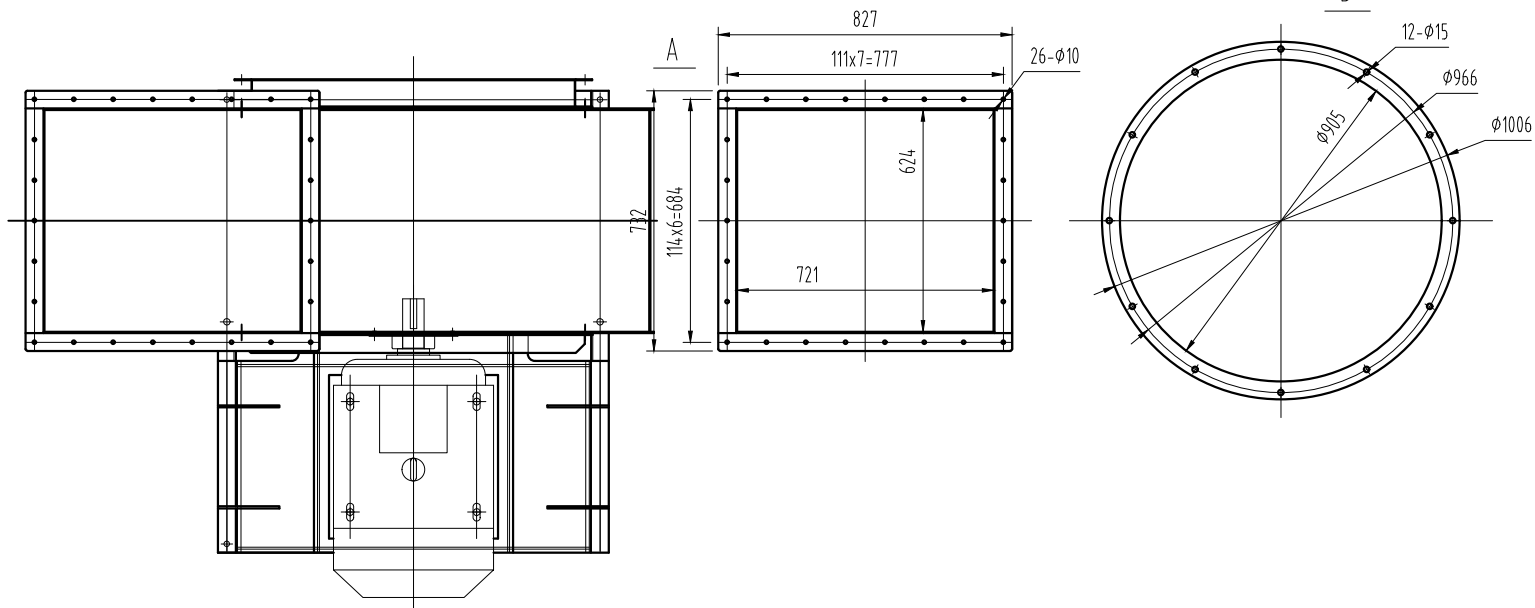
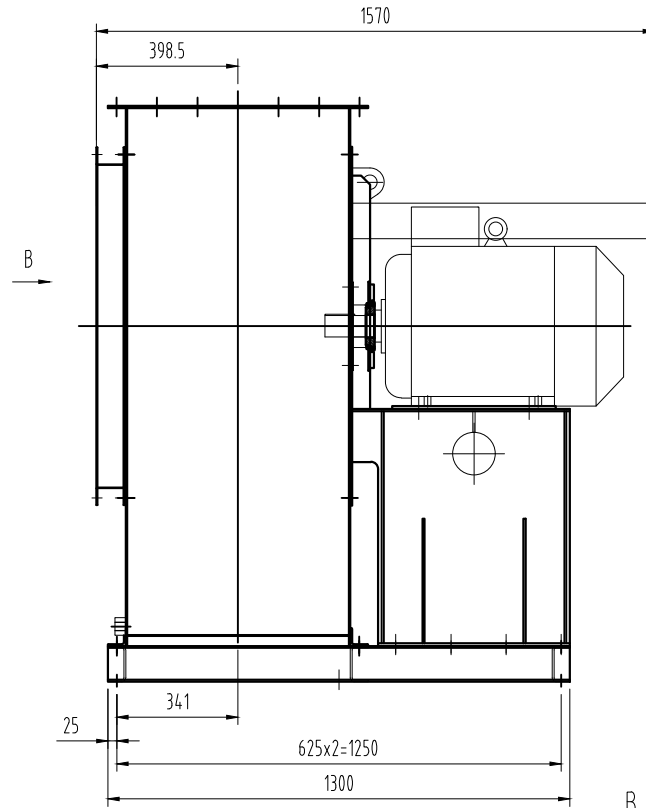
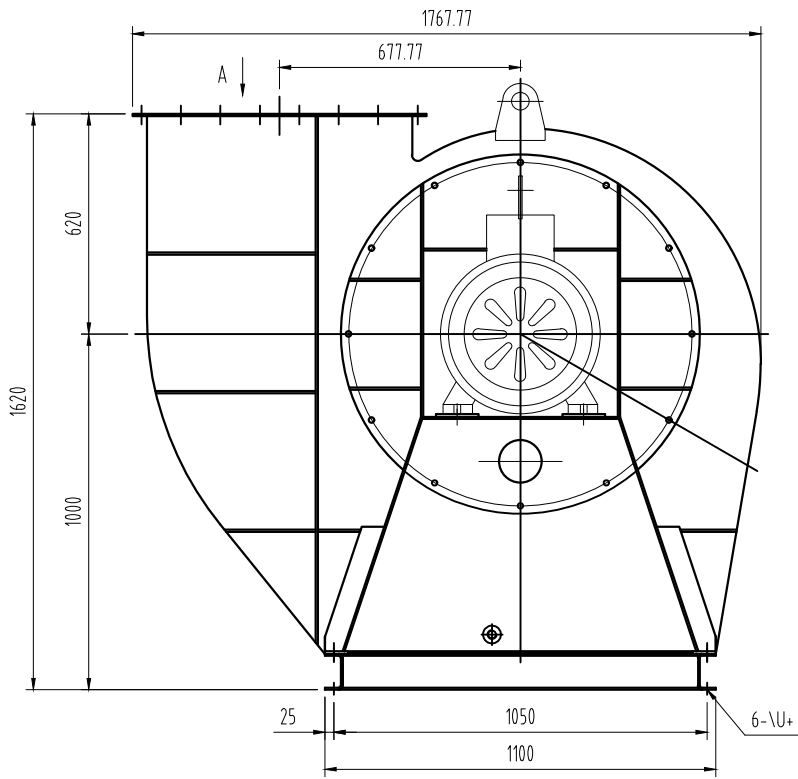

Arama & Benet

www.arama-benet.com

REV.02 06.2024

Arama and Benet reserves the right to make changes at any time and without prior notice.