

KTF-II Series Centrifugal Fan



Arama & Benet

Air Engineering Solutions

info@arama-benet.com
www.arama-benet.com

PRODUCT NAME:
KTF-II Series Centrifugal Fan

PRODUCT TYPE:
KTF1000C-II-30.0kW-6-90°R

Weight include motor:
730 kg

Finish: Painted
Color: RAL 7024

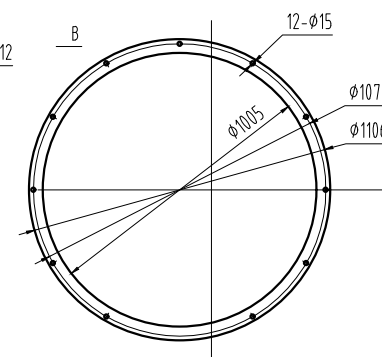
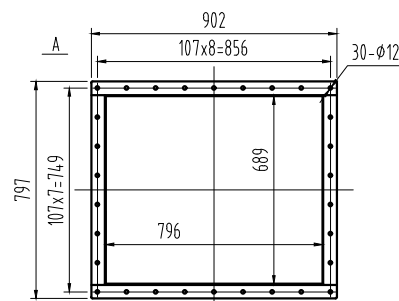
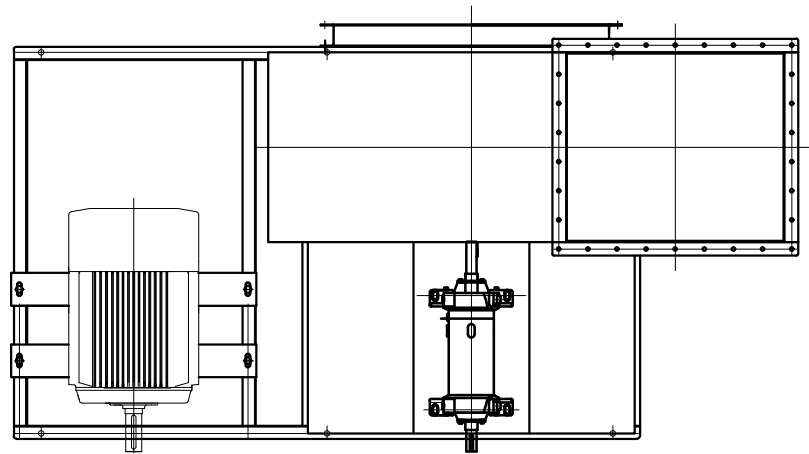
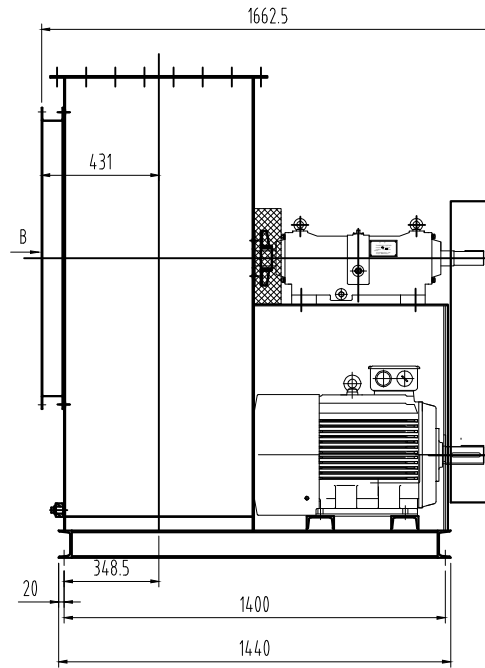
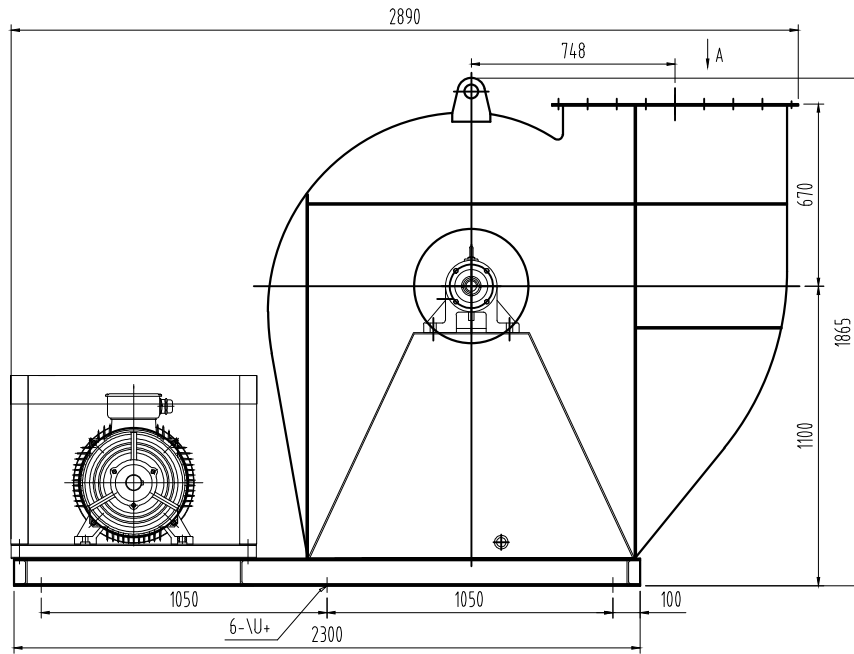

Arama & Benet

www.arama-benet.com

REV.02 06.2024

Arama and Benet reserves the right to make changes at any time and without prior notice.