

1. Panel Washable metal Filter [G2]
2. Amerglas syntetic Filter [G2]
3. Pleated Filer [G4]
4. Electrostatic precipitator collection cell
5. Activated Carbon Filter
6. Removable grease tray
7. EP Power supply
8. Base Frame(option upon request)
9. Weld on Lifting Lugs(option upon request)
10. Brass valve

ITEM No.	Filter Type	Grade	Filter size	Reted Face Velocity (At FULL capacity)	Filter Flow capacity	New Condition Resistance (Pa)	Final Condition (Pa)	Filter QTY	WEIGHT [kg]	
1	Panel Washable Metal Filter	G2	595x595x45	650 FPM 3.30 m/S	2470 CFM 4200 m³/h	5 Pa	55 Pa	12	28.8	
2	Amerglas Syntetic Filter	G2	595x595x45	492 FPM 2.5 m/S	1874 CFM 3186 m³/h	75 Pa	250 Pa	12	6	
3	Pleated Filter	G4	595x595x45	516 FPM 2.58 m/S	1967 CFM 3344 m³/h	69 Pa	250 Pa	12	6	
4	Electrostatic collection cell	N/A	550x480x340	4.85 m/S	1823 CFM 3100 m³/h	85 Pa	105 Pa	12	156	
5	Activated Carbon Filter	N/A	595x595x30	51 FPM 0.26 m/S	203 CFM 345 m³/h	55 Pa	155 Pa	120	792	
Initial Pressure: 289 Pa				Recommended final Pressure: 815 Pa			Total weight: 1546.19 [kg]			

Project NAME:		Product Type: ABFU-720-S-EP		Project Number:	
	NAME	DATE	<small>UNLESS OTHERWISE SPECIFIED: DIMENSIONS ARE IN MILLIMETERS GENERAL TOLERANCES: X ±.5 X.X ±0.2 X.XX ±0.05 ANGULAR: ±1°</small>	Product Name: Ecology UNIT	
DRAFT	Andrey S	24/10/2023		Description: ABFU-SERIES	
DESIGNER	Andrey S	24/10/2023			
APPROVED	Luke Benet	24/10/2023			
CHECKED	Luke Benet	24/10/2023			
MATERIAL:	Galvanized steel	WEIGHT: 558 [kg]	FINISH: RAL-7024		
TYPE: A3	SCALE: 1:20	REVISION 04	SHEET 1 OF 2		

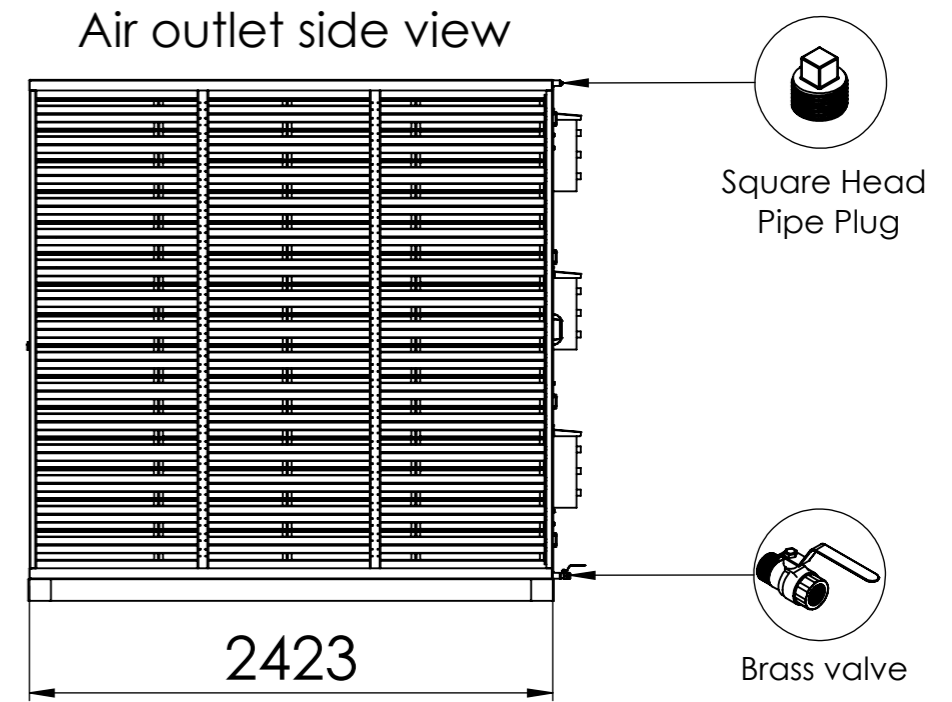

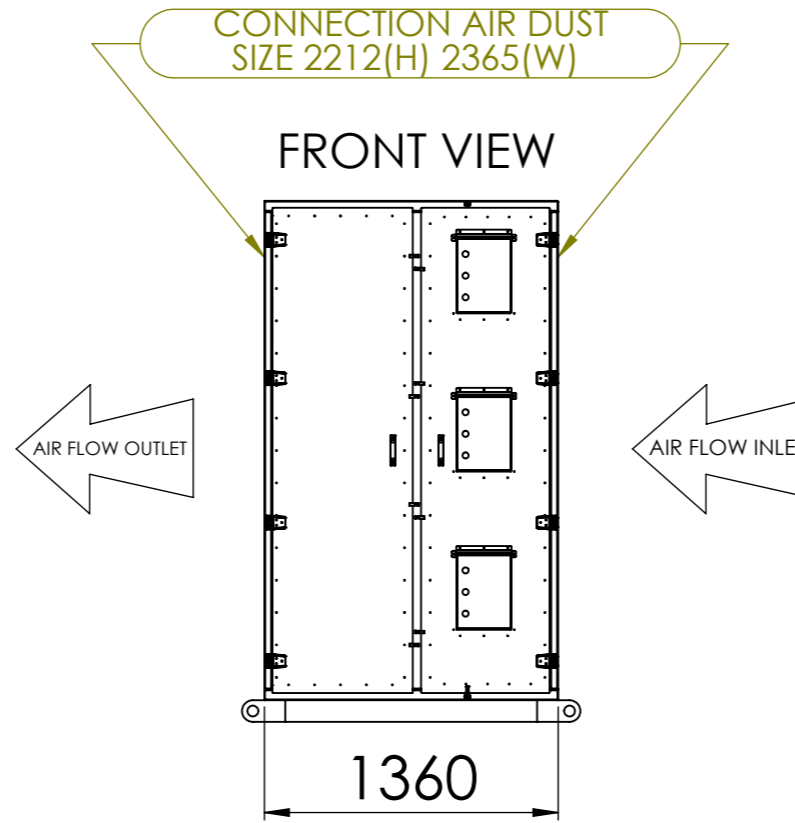
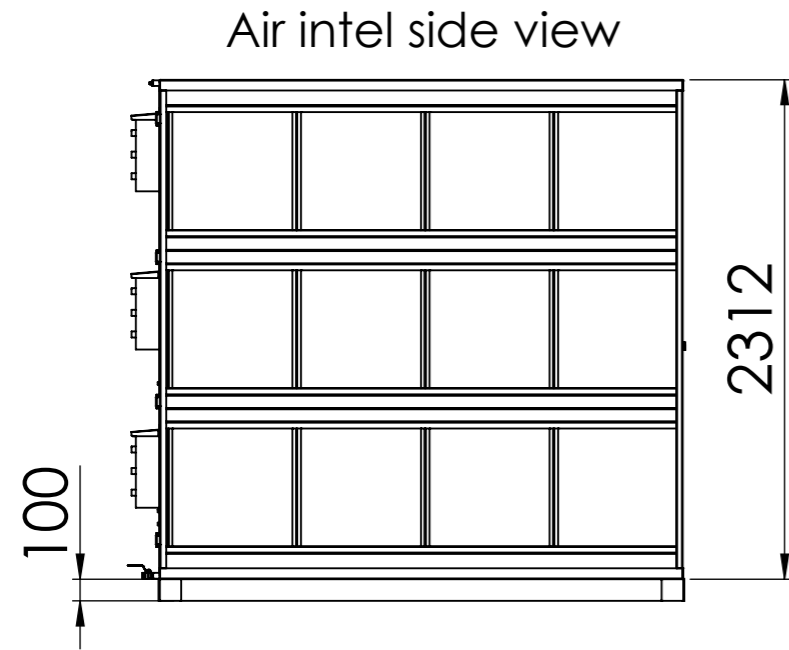

INSTALLATION FRAME

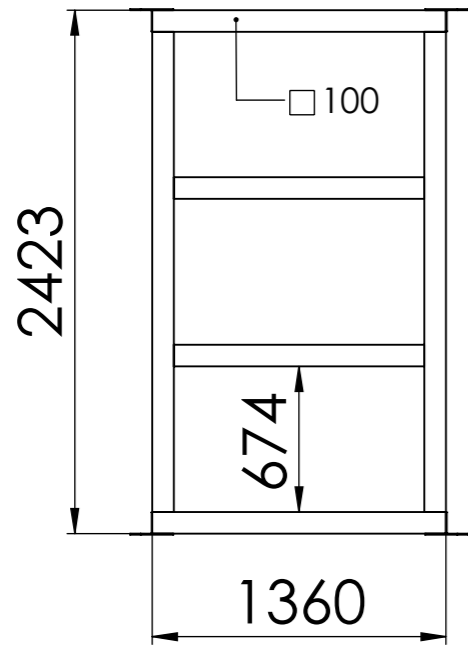

OVER VIEW

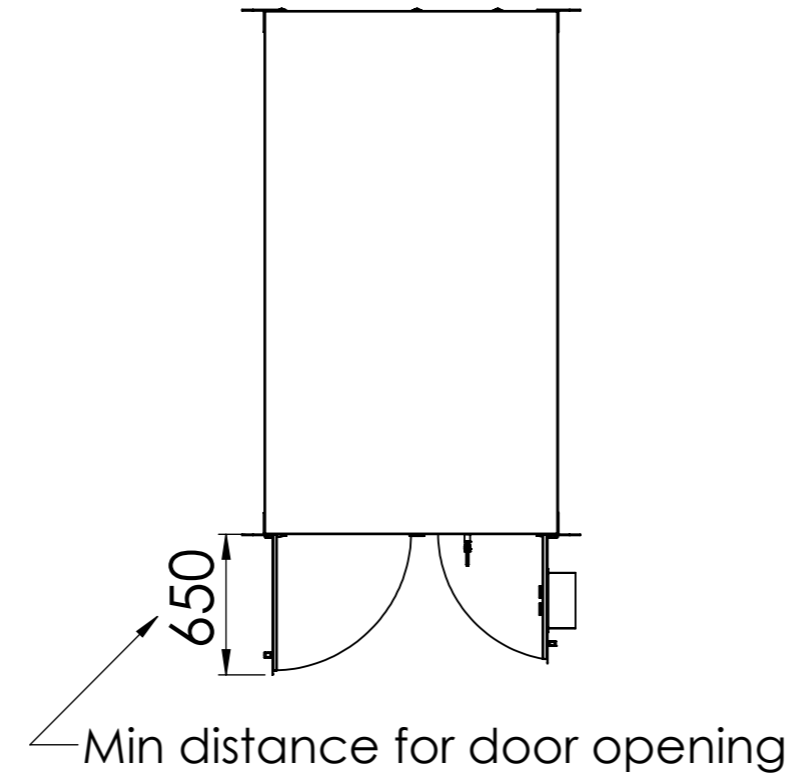

BACK VIEW

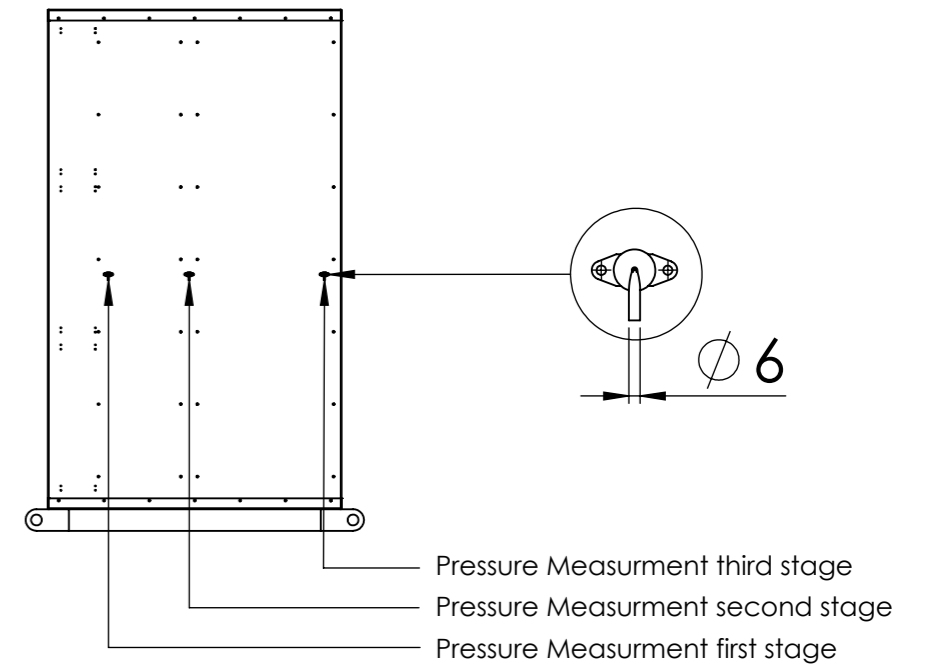

ITEM No.	Filter Type	Grade	Filter size	Reted Face Velocity (At FULL capacity)	Filter Flow capacity	New Condition Resistance (Pa)	Final Condition (Pa)	Filter QTY	WEIGHT [kg]	
1	Panel Washable Metal Filter	G2	595x595x45	650 FPM 3.30 m/S	2470 CFM 4200 m³/h	5 Pa	55 Pa	12	28.8	
2	Amerglas Syntetic Filter	G2	595x595x45	492 FPM 2.5 m/S	1874 CFM 3186 m³/h	75 Pa	250 Pa	12	6	
3	Pleated Filter	G4	595x595x45	516 FPM 2.58 m/S	1967 CFM 3344 m³/h	69 Pa	250 Pa	12	6	
4	Electrostatic collection cell	N/A	550x480x340	4.85 m/S	1823 CFM 3100 m³/h	85 Pa	105 Pa	12	156	
5	Activated Carbon Filter	N/A	595x595x30	51 FPM 0.26 m/S	203 CFM 345 m³/h	55 Pa	155 Pa	120	792	
Initial Pressure: 289 Pa				Recommended final Pressure: 815 Pa			Total weight: 1546.19 [kg]			

Project NAME:		Product Type: ABFU-720-S-EP		Project Number:	
NAME		DATE		Product Name: Ecology UNIT	
DRAFT	Andrey S	24/10/2023		<small>UNLESS OTHERWISE SPECIFIED: DIMENSIONS ARE IN MILLIMETERS GENERAL TOLERANCES: X±.5 X.X±0.2 X.XX±0.05 ANGULAR:±1°</small>	
DESIGNER	Andrey S	24/10/2023			
APPROVED	Luke Benet	24/10/2023			
CHECKED	Luke Benet	24/10/2023			
MATERIAL:	Galvanized steel	WEIGHT:	558 [kg]		
TYPE: A3	SCALE:1:35	REVISION	04	SHEET 2 OF 2	

