

Drain Pipe
1 inch

280

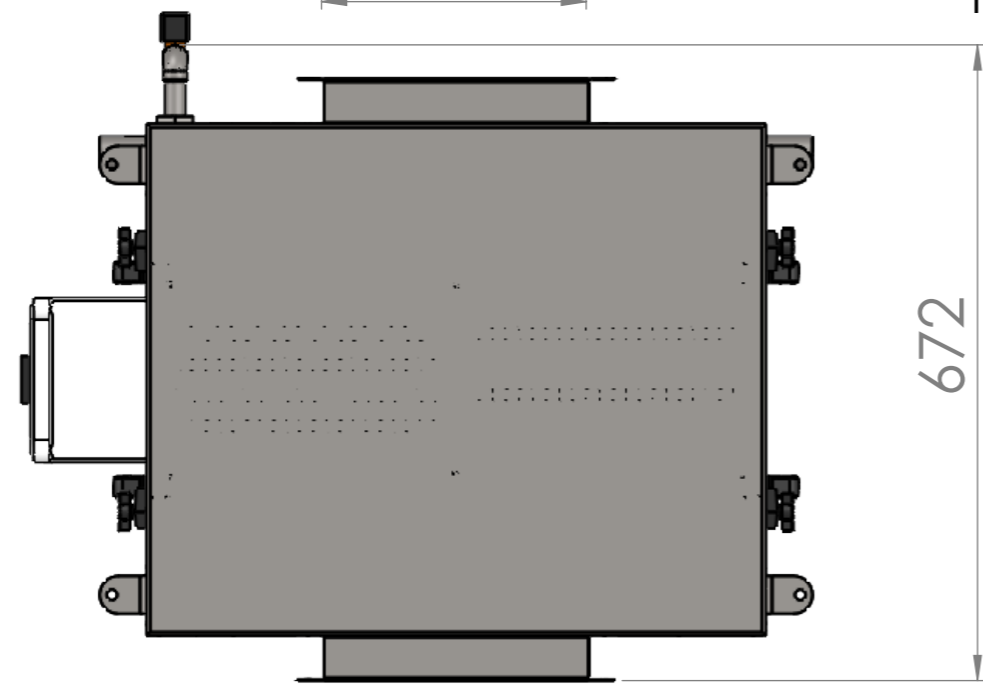

672

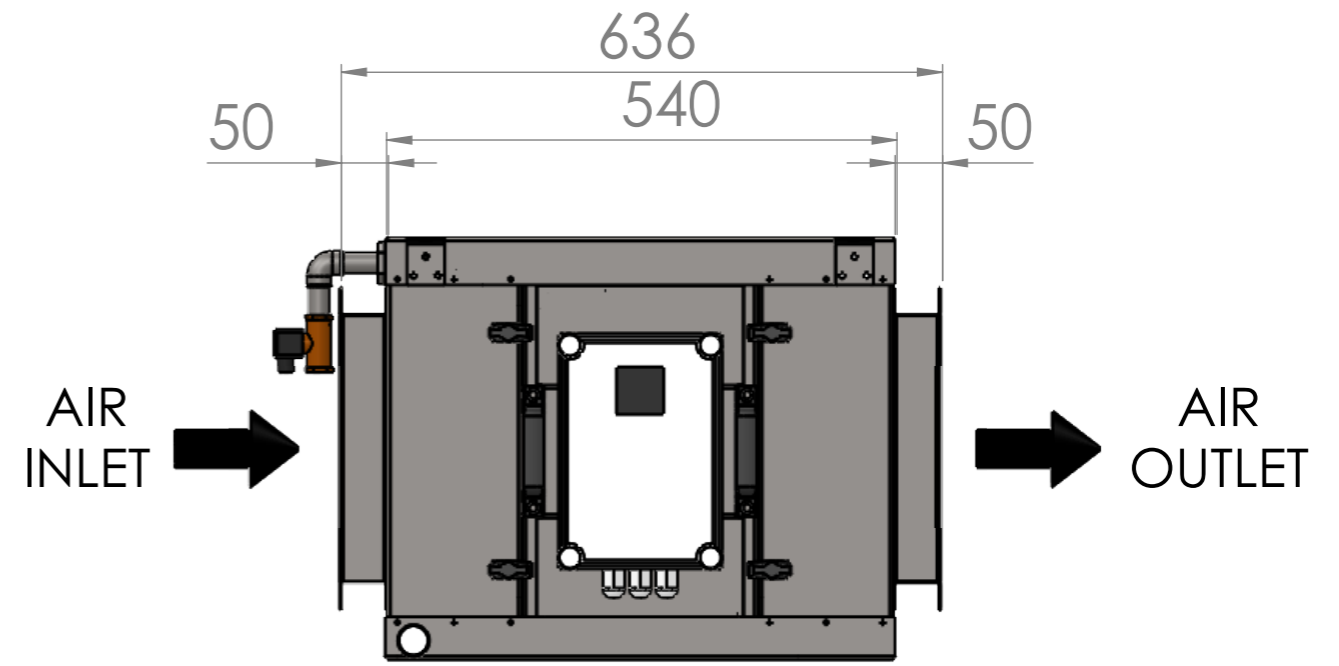

AIR
INLET

AIR
OUTLET

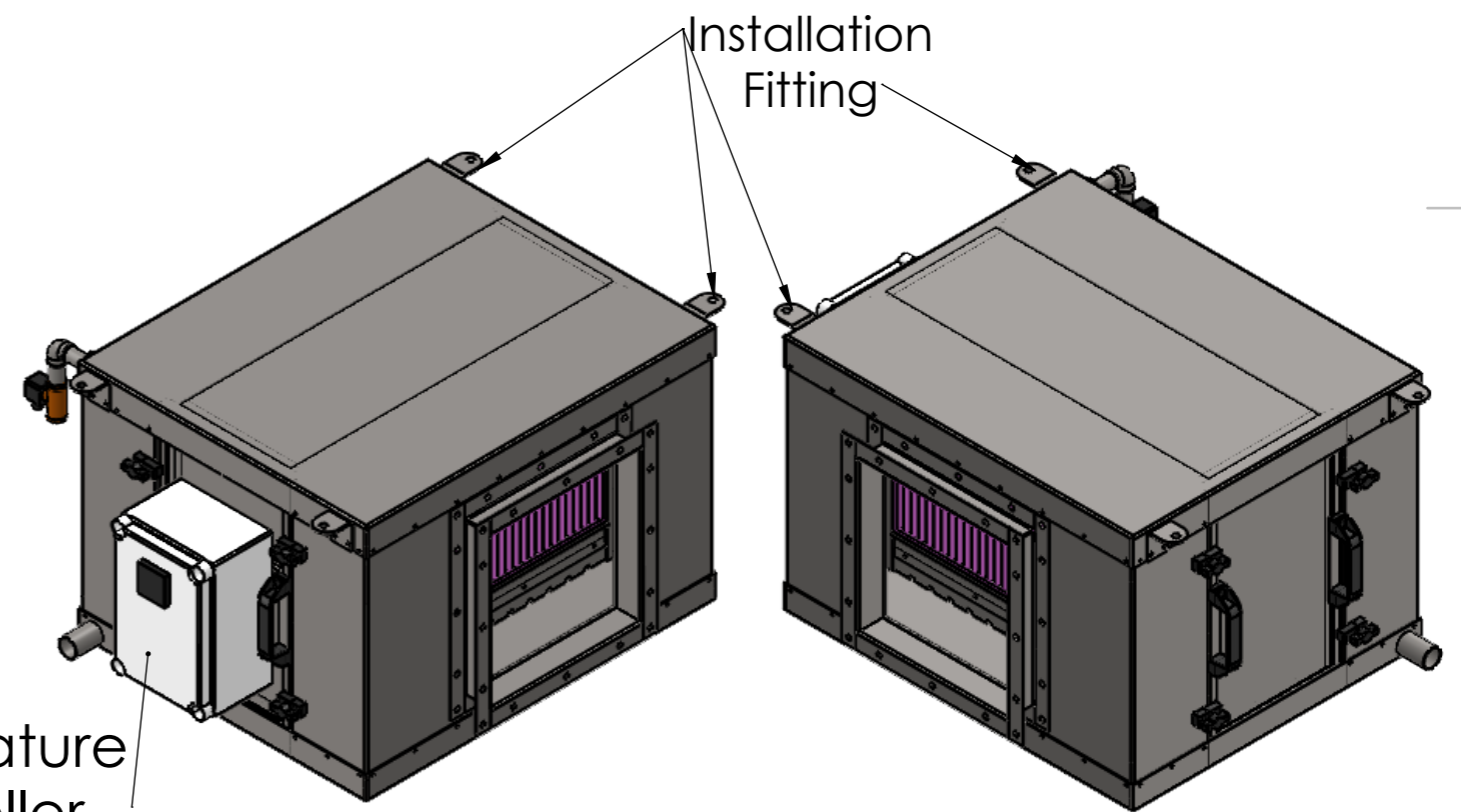

Temperature
Controller

Model: ABCB-1000

Airflow Volume: 1000 CFM

Water consumption: 1 Bar-18L/h

2 Bar-25L/h

3 Bar-31L/h

Power consumption: 230V-2A

Drainage connection: 1"

ALL DIMENSION ARE IN mm	NAME	DATE	P/N:	ABCB-1000
DIMENSIONS APPLY AFTER COATING	DRAFT			
	DESIGNER			
	CHECKED	25-06-17	Description:	Cross Box ABCB-1000
	APPROVED		PROJECT NAME:	
UNLESS OTHERWISE SPECIFIED: DIMENSIONS ARE IN MILLIMETERS GENERAL TOLERANCES: X±.5 X.X±0.2 X.XX±0.05 ANGULAR:±1°	MATERIAL: Stainless Steel, 304	FINISH: F4	SCALE:1:10	SHEET 1 OF 1
	WEIGHT: 60 [kg]	TYPE: W A3	REVISION 01	

